

Construção do Reforço de Potência de Salamonde II

Bacia do Cávado-Rabagão (Vieira do Minho), Portugal

Improvement Salamonde Dam

Bacia do Cávado-Rabagão (Vieira do Minho), Portugal

Work Description

Execution of all construction works of the new Hydroelectric Power Salamonde II which is intended to strengthen power installed in hydroelectric Salamonde, situated in Vieira do Minho, Braga district.

Scope of work

Independent and underground hydraulic circuit with 2.2 km total length, composed of the following elements:

- Water intake in the Albufeira Salamonde;
- Section of underground adduction;
- Section of restitution between the Central and the connection to the balancing chimney;
- Balancing chimney;
- Tunnel Return;
- Restitution in Albufeira Caniçada;
- Downstream channel dug in the bed of the River Cávado;
- Underground Central;
- Building support and substation;
- Access tunnels and attack;
- Heap and diversion of Rio Mau;
- Cofferdams Water Outlet, restitution and complementary flood spillway;
- Complementary Flood spillway with supply and assembly of equipment.

Main quantities:

Earth moving: 765 000 m³

Concrete: 130,000 m³

Steel: 9,100,000 kg

Construction of cofferdams

- Water intake in the Albufeira Salamonde
- Complementary Flood spillway, Albufeira Salamonde
- Restitution in Albufeira Caniçada



Resumo da Obra

Work Summary

Cliente	EDP – Gestão da Produção de Energia, SA	<i>Client</i>
Tipo de contracto	Valor Global / Lump-sum	<i>Contract type</i>
Construtores	Seth, SA (em consórcio)	<i>Contractor</i>
Data de construção	2011-2015	<i>Construction period</i>
Custo	€ 125.000.000,00	<i>Cost</i>

Açude Insuflável de Abrantes *Inflatable Weir at Abrantes*

As part of a consortium **Seth** concluded the River Tagus Inflatable Weir job at Abrantes. The job, awarded by the Abrantes City Council, was finalised in 670 working days and it included the design of the project and the construction of what is, to date, the Iberian Peninsula's biggest weir of its type.

One of the goals of this job was to create a reflecting pool upstream of the weir at a predetermined level, allowing the reservoir created between the city of Abrantes and Rossio ao Sul do Tejo to be used for leisure and entertainment purposes.

Fundamentally, the weir comprises a reinforced concrete body with a portico-shaped cross section about 15 metres wide and 200 metres long, with a variable depth of about 6 metres. The superstructure comprises 4 piers 5.5 metres tall that form four spans that can be blocked by means of cylindrical rubber bodies, the first having a perimeter of 1.20 m and the others 3.2 m. The 5th span comprises a reinforced concrete sluice.

Of the complementary organs, attention is drawn to the reinforced fish house (a zigzag labyrinth) located on the left bank surrounding the respective abutment, and to the control room where the equipment required to operate the weir is located (insufflators, valves, electrical installation, automation, emergency generators, plc-automated control, etc.).

The access roads to the weir are also part of the project.

Main quantities of work:

Concrete: 25 000 m³

Rubble concrete: 5 000 m³

Shuttering: 9 500 m²

Steel: 1 500 tonnes

Accesses: 8 800 m²

Excavation: 16 000 m³

Excavation in rock: 8 500 m³

Inflatable sluice gates:

Span 1 (weight 2.1 tonnes – thickness 10.8 mm)

Spans 2, 3 & 4 (weight 3 x 4.7 tonnes
– thickness – 13.5 mm)



Resumo da Obra

Work Summary

Cliente
Projectista
Tipo de contrato
Data de construção
Custo

Câmara Municipal de Abrantes
CENOR – Projectos de Engenharia, Lda
Concepção/Construção
2004-2007 (670 days)
EUR 9.450.290,00

Client
Architect & Engineer
Contract type
Construction period
Cost



Execução de Tomada de Água
Central de Ciclo Combinado de Lares (Figueira da Foz)
Water Intake and Discharge Pipping
Combined Cycle Central Power (Lares - Figueira da Foz, Portugal)

Work description

Seth , S.A. has complete in consortium the contract for the execution of the Water Intake and Discharge Pipping for the EDP Combined Cycle Central Power, at Lares (Figueira da Foz).

The work consisted in implementing the aforementioned water outlet at the Mondego River and the work realized basically water intake and pumping wells, in reinforced concrete structures, executed by the method of molded walls and the micro tunnelling execution water intake and discharge pipping.

During the contract it was also need to implement some cofferdams in "Larsen" sheet piles.

Around the water intake box was performed a slab in "Reno mattresses", over a rock fill foundation with about 1.0 m thick, for protection of this slab were performed "wing" walls in gabions .



Main jobs:

- Micro tunnelling
- Horizontal drilling
- Shapped walls
- Cofferdams
- Dredging
- Gabions and mattresses underwater
- Submerged concrete



Resumo da Obra

Work Summary

Cliente	EDP – Energias de Portugal, SA	<i>Client</i>
Tipo de contrato	Valor Global Lump Sum	<i>Contract type</i>
Data de construção	2008-2009	<i>Construction period</i>
Custo	EUR 2.990.000,00	<i>Cost</i>



Açude Insuflável de Coruche *Inflatable Weir at Coruche*

Seth completed the work of the Inflatable Weir (river Sorraia) in Coruche.

The work of Dam Coruche, launched by the Municipality of Coruche, is part of the Recovery Plan Marginal Sorraia River allowing residents to enjoy a new social facilities, unique features.

The water mirror thus created upstream of the dam enhances the practice of fishing contests and events, recreational motorboats, and other footpaths.

The dam consists of a main body, reinforced concrete, crossing the entire river, and a metal catwalk, a pedestrian extension of 62 meters, which allows the passage from one to the other side.

The indirect foundations of the complex consist of a set of 62 reinforced concrete piles, cast on the ground, with 800 mm diameter and 16 m deep.

The inflatable weir is still complex consists of:

- A house of Control
- A house of Command
- An observation room for fish
- A fish ladder.

Main quantities of work

Concrete: 3.970 m³

Rubble concrete: 45 m³

Shuttering: 974 m²

Steel: 272.000 Kg

Accesses: 800 m³

Excavation: 2.300 m³

Inflatable sluice gates:

Span 1: c/ 30 meters

Span 2: c/ 30 meters

Diameter: 2,5 meters

Material: semi-synthetic rubber reinforced with polyester mesh

Architect and Engineer: Hidroprojecto



Resumo da Obra

Work Summary

Cliente	Câmara Municipal de Coruche	<i>Client</i>
Tipo de contrato	Turn-key	<i>Contract type</i>
Data de construção	2011-2012	<i>Construction period</i>
Custo	EUR 2.291.885,00	<i>Cost</i>

Rehabilitation of the dams at Arrabalde and Salgadas

Page 1 of 2

Inflatable Weir at Arrabalde

This dam is located approximately 14.3 kilometers to the river Lis, a section located to the west of the city of Leiria next "field of the fair." This hydraulic structure is fundamental part of the irrigation system of the fields of the Valley of Lis. It is through this that creates the reservoir water level necessary to enable the abstraction of water for irrigation.

The rehabilitation of the dam Arrabalde's main goal was to allow the automatic triggering of the two gates, inserted in the body of the dam, and water intakes in order to allow, in accordance with the needs of water and streams and tributaries downstream requested, optimization of their operation.

From the structural point of view, the solution rehabilitation forced the demolition of the old central area of the dam wall and sill, for placement of new gates. This intervention took place, on both sides, with the curtains crimping sheet pile walls in masonry of the dam, to ensure the stability of the work and the surrounding land during the demolition of existing walls and the sill.

The implementation of the new dam, comprised the construction of two side meetings, a central pillar and from two wells, one on each bank, which host the servo motors driving the floodgates. The work also included the automation of the two water intakes for irrigation.



Inflatable at Arrabalde: view downstream of the two spans, cofferdam and house to electrical controls

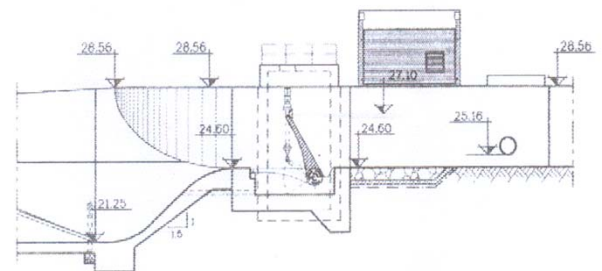

Tipo de comportas	Charneira
Largura dos vãos obturados	7,75m
Altura dos vãos obturados	2,50m
Número de comportas	2
Cota de soleira	24,60m
Cota do NPA	27,10m
Cota da plataforma	28,56m
Carga máxima	2,5 m.c.a.
Manobra da comporta	Em plena carga
Manobra da ensecadeira	Em águas equilibradas



Inflatable weir at Arrabalde: river to flow only in the lower tubes, during the execution of work

Resumo da Obra

Work Summary

Client	IHERA - Instituto de Hidráulica, Engenharia Rural e Ambiente
Project	HIDROPROJECTO – Engenharia e Gestão, SA
Tipo de contrato	Turnkey
Data de construção	November 2000 to April 2001
Cost	1.920.371,91 Euros



Rehabilitation of the dams at Arrabalde and Salgadas

Page 2 of 2

AÇUDE DAS SALGADAS

The dam of Salted located approximately 30 kilometers to the river Lys, near Mount Royal, a section of the bed and settled contributes more as a fundamental part of the irrigation system of the fields of the Valley of Lis. The rehabilitation of the dam's main goal was to replace the existing structure that was obsolete (about 50 years), creating a plan to allow sufficient water supply to the needs of water and flow downstream requested by making water in the left margin. The work consisted of a "inflatable dam" which broadly comprises a threshold based on eight concrete piles with 60 cm diameter and depth between 18 and 24 meters, in which a chamber is recessed synthetic rubber reinforced. The rehabilitation also included the automation of irrigation water outlet.



Açude das Salgadas em plena carga (pormenor do insuflável)

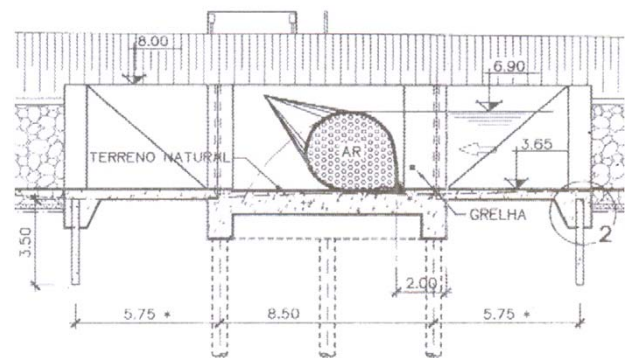

Açude das Salgadas: vista de jusante da margem direita
(açude a descarregar com o insuflável a esvaziar)

Tipo de comporta	Insuflável
Largura do vão obturado	7,00m
Altura do vão obturado	3,25m
Inclinação das paredes laterais	1 (V) : 1 (H)
Número de comportas	1
Cota da soleira	3,65m
Cota do NPA	6,90m
Cota da plataforma	8,00m

Resumo da Obra *Work Summary*

Cliente	IHERA - Instituto de Hidráulica, Engenharia Rural e Ambiente
Projectista	HIDROPROJECTO – Engenharia e Gestão, SA
Tipo de contrato	Chave-na-Mão
Data de construção	Novembro de 2000 a Abril de 2001
Custo	1.920.371,91 euros (PTE 385.000.000) os dois açudes

